

# YGE 280 SERIES

YL290P-35b  
YL285P-35b  
YL280P-35b  
YL275P-35b  
YL270P-35b



## ABOUT YINGLI GREEN ENERGY

Yingli Green Energy Holding Company Limited (NYSE: YGE) is one of the world's largest fully vertically integrated PV manufacturers, which markets its products under the brand "Yingli Solar". With over 2GW of modules installed globally, we are a leading solar energy company built upon proven product reliability and sustainable performance. We are the first renewable energy company and the first Chinese company to sponsor the FIFA World Cup™.

## PERFORMANCE

- High efficiency, multicrystalline solar cells with high transmission and textured glass deliver a module efficiency of up to 14.9%, minimizing installation costs and maximizing the kWh output of your system per unit area.
- Tight positive power tolerance of 0W to +5W ensures you receive modules at or above nameplate power and contributes to minimizing module mismatch losses leading to improved system yield.

## QUALITY & RELIABILITY

- Robust, corrosion resistant aluminum frames independently tested to withstand wind loads of up to 2.4kPa and snow loads of up to 5.4kPa ensuring a stable mechanical life for your modules.
- Module packaging optimized to protect product during transportation and minimize on-site waste.
- Modules independently tested to ensure conformance with certification and regulatory standards.
- Manufacturing facility certified by TÜV Rheinland to ISO 9001:2008, ISO 14001:2004 and BS OHSAS 18001:2007.

## WARRANTIES

- 10-year limited product warranty<sup>1</sup>.
- Limited power warranty<sup>1</sup>: 10 years at 91.2% of the minimal rated power output, 25 years at 80.7% of the minimal rated power output.

<sup>1</sup> In compliance with our Warranty Terms and Conditions.

## QUALIFICATIONS & CERTIFICATES

IEC 61215, IEC 61730, MCS, CE, ISO 9001:2008, ISO 14001:2004, BS OHSAS 18001:2007, SA 8000, PV Cycle

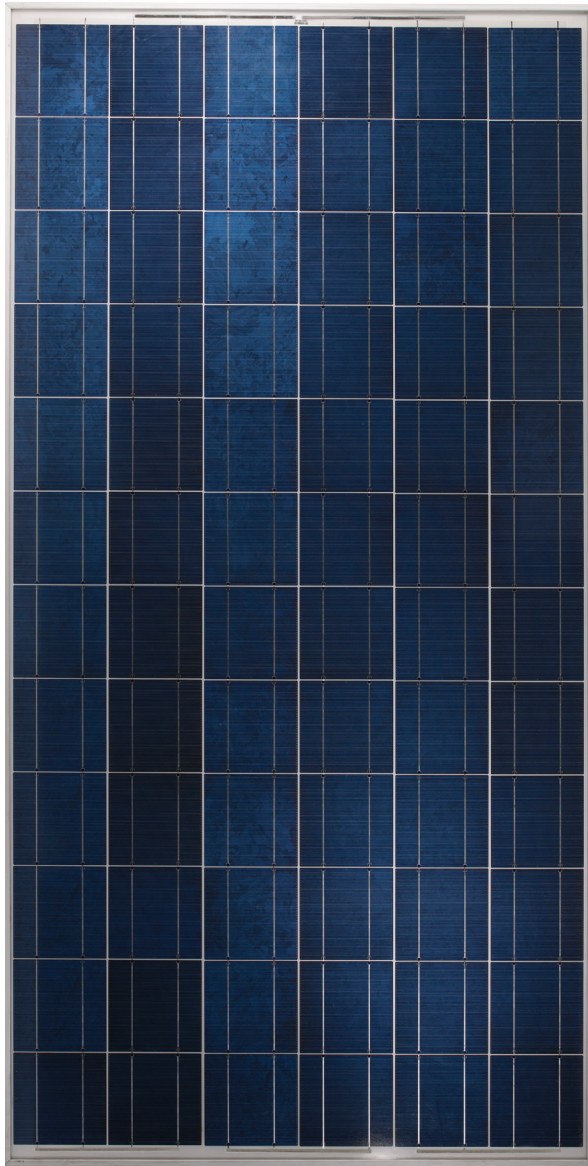

# YGE 280 SERIES

## ELECTRICAL PERFORMANCE

### Electrical parameters at Standard Test Conditions (STC)

Module name			YGE 290	YGE 285	YGE 280	YGE 275	YGE 270
Module type			YL290P-35b	YL285P-35b	YL280P-35b	YL275P-35b	YL270P-35b
Power output	$P_{max}$	W	290	285	280	275	270
Power output tolerances	$\Delta P_{max}$	W	-0 ~ +5				
Module efficiency	$\eta_m$	%	14.9	14.7	14.4	14.1	13.8
Voltage at $P_{max}$	$V_{mpp}$	V	35.8	35.5	35.5	35.5	35.3
Current at $P_{max}$	$I_{mpp}$	A	8.10	8.02	7.89	7.75	7.65
Open-circuit voltage	$V_{oc}$	V	45.3	45.0	45.0	45.0	44.8
Short-circuit current	$I_{sc}$	A	8.62	8.50	8.35	8.30	8.20

STC: 1000W/m<sup>2</sup> irradiance, 25°C module temperature, AM1.5g spectrum according to EN 60904-3.  
Ave. efficiency reduction of 5% at 200W/m<sup>2</sup> according to EN 60904-1.

### Electrical parameters at Nominal Operating Cell Temperature (NOCT)

Power output	$P_{max}$	W	210.6	207.0	203.3	199.7	196.1
Voltage at $P_{max}$	$V_{mpp}$	V	32.3	32.0	32.0	32.0	31.8
Current at $P_{max}$	$I_{mpp}$	A	6.53	6.46	6.36	6.25	6.17
Open-circuit voltage	$V_{oc}$	V	41.3	41.1	41.1	41.1	40.9
Short-circuit current	$I_{sc}$	A	6.98	6.89	6.76	6.72	6.64

NOCT: open-circuit module operation temperature at 800W/m<sup>2</sup> irradiance, 20°C ambient temperature, 1m/s wind speed.

## THERMAL CHARACTERISTICS

Nominal operating cell temperature	NOCT	°C	46 +/- 2
Temperature coefficient of $P_{max}$	$\gamma$	%/°C	-0.45
Temperature coefficient of $V_{oc}$	$\beta_{Voc}$	%/°C	-0.37
Temperature coefficient of $I_{sc}$	$\alpha_{Isc}$	%/°C	0.06

## OPERATING CONDITIONS

Max. system voltage	1000V <sub>DC</sub>
Max. series fuse rating	15A
Limiting reverse current	Do not apply external voltages larger than $V_{oc}$ of the module.
Operating temperature range	-40 to 85°C
Max. static load, front (e.g., snow and wind)	5400Pa
Max. static load, back (e.g., wind)	2400Pa
Max. hailstone impact (diameter / velocity)	25mm / 23m/s

## CONSTRUCTION MATERIALS

Front cover (material / type / thickness)	low-iron tempered glass / 4.0mm
Cell (quantity / material / type / dimensions)	72 / multicrystalline / 156mm x 156mm
Encapsulant (material)	ethylene vinyl acetate (EVA)
Frame (material / color / anodization color)	anodized aluminum alloy / silver / clear
Junction box (protection degree)	IP65
Cable (length / cross-sectional area)	1200mm / 4mm <sup>2</sup>
Plug connector (type / protection degree)	MC4 / IP67 or Amphenol H4 / IP68

- Due to continuous innovation, research and product improvement, the specifications in this product information sheet are subject to change without prior notice. The specifications may deviate slightly and are not guaranteed.
- The data do not refer to a single module and they are not part of the offer, they only serve for comparison to different module types.

Yingli Green Energy Holding Co. Ltd.

service@yinglisolar.com

Tel: +0086-312-8929802

**YINGLISOLAR.COM**

© Yingli Green Energy Holding Co. Ltd. | DS\_YL280P-35b\_2BB\_EU\_EN\_201109\_v02.6

## GENERAL CHARACTERISTICS

Dimensions (L / W / H)	1970mm / 990mm / 50mm
Weight	26.8kg

## PACKAGING SPECIFICATIONS

Number of modules per pallet	21
Number of pallets per 40' container	24
Packaging box dimensions (L / W / H)	1985mm / 1140mm / 1125mm
Box weight	613kg

Unit: mm

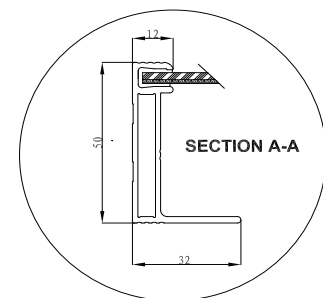
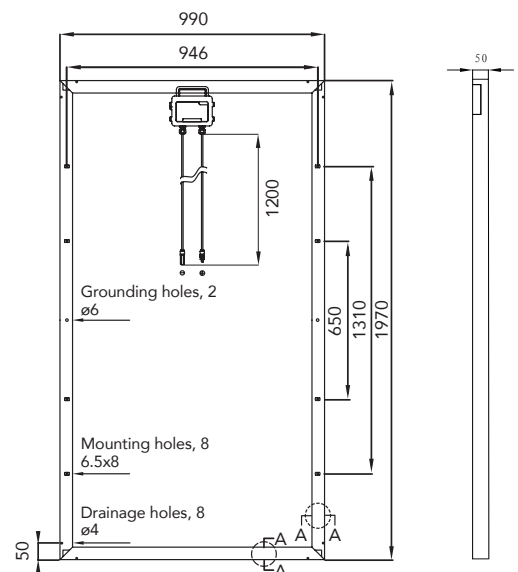

Warning: Read the instruction manual in its entirety before handling, installing, and operating Yingli Solar modules.

Our Partners:

