



Revision Date Aug 26, 2011 | Applicable for UL certified products in the United States and Canada.

This manual applies to photovoltaic modules (“PV modules”, also commonly known as solar panels) manufactured by Yingli Green Energy Holding Co., Ltd. (“Yingli Solar”), and is explicitly written for qualified professionals (“Installer” or “Installers”), including without limitation licensed electricians and NABCEP-Certified PV Installers.

INTRODUCTION

Thank you for choosing Yingli Solar as your PV module provider. We appreciate your business! This manual contains important information pertaining to the electrical and mechanical installation and maintenance of PV Modules, and contains safety information that you must read carefully and be familiar with before handling, installing, and/or maintaining Yingli Solar PV modules.

Yingli Solar does not assume responsibility and expressly disclaims liability for losses, damages, or expenses arising out of, or in any way connected with this Installation and User Manual. Yingli Solar assumes no responsibility for any infringement of patents or other rights of third parties, which may result from using Yingli Solar PV modules. No license is granted expressly or by implication or under any patent or patent rights. The information in this manual is believed to be reliable, but does not constitute an expressed or implied warranty. Yingli Solar reserves the right to make changes to its PV modules and other products, their specifications, or this manual without prior notice.

Yingli Solar and its subsidiaries are not liable for any damages caused by inappropriate installation, use, or maintenance of Yingli Solar PV modules, including without limitation damages, losses, and expenses caused by non-observance of the instructions of this manual or caused by or in connection with products of other manufacturers.

This manual refers to UL certified products and conforms to UL standard 1703: Flat Plate Photovoltaic Modules and Panels. For PV module installations to be performed in Canada, the installation shall be in accordance with CSA C22.1, Safety Standard for Electrical Installations, Canadian Electrical Code, Part 1.

This Installation and User Manual is available in different languages. In cases of discrepancy between versions, the English language version shall control.

Failure to comply with the requirements listed in this manual will invalidate the Limited Warranty for PV Modules as provided by Yingli Solar at the time of sale to the direct customer. Additional recommendations are provided to enhance safety practices and performance results. Please provide a copy of this manual to the PV system owner for their reference, and inform them of all relevant aspects of safety, operation, and maintenance.

SAFETY

General

You must understand and follow all applicable local, state, and federal regulations and standards for building construction, electrical design, fire, and safety, and must check with local authorities to determine applicable permitting requirements before attempting to install or maintain PV modules.



Rooftop PV systems should only be installed on dwellings that have been formally analyzed for structural integrity, and confirmed to be capable of handling the additional weighted load of PV system components, including PV modules, by a certified building specialist or engineer.

For your safety, do not attempt to work on a rooftop until safety precautions have been identified and taken, including without limitation fall protection measures, ladders or stairways, and personal protective equipment (PPE).

For your safety, do not install or handle PV modules under adverse conditions, including without limitation strong or gusty winds, and wet or frosted roof surfaces.

The flat-plate PV module construction consists of a laminated assembly of solar cells encapsulated within an insulating material with a rigid glass surface and an insulated substrate. The laminated assembly is supported by an aluminum frame that is also used for mounting the module. See Figure 1 for an illustration of the PV module components.

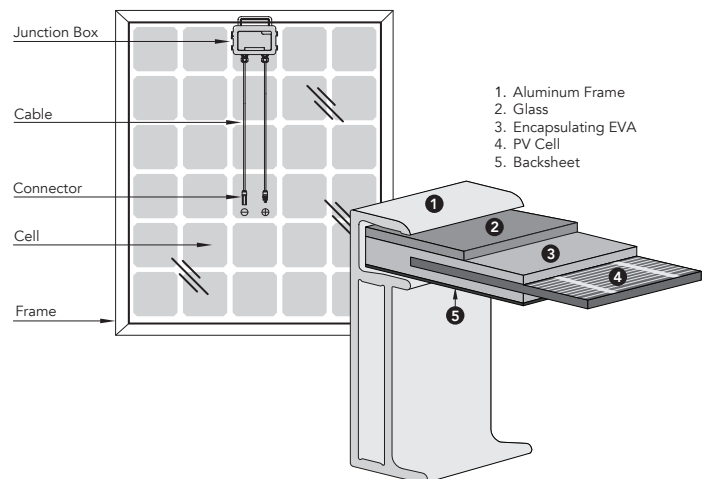
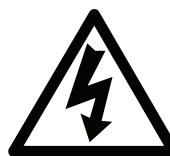

Figure 1: Module components and cross-section of the laminated assembly

Electrical



PV modules can produce current and voltage when exposed to light of any intensity. Electrical current increases with higher light intensity. DC voltage of 30 Volts or higher is potentially lethal. Contacting the live circuitry of a PV system operating under light can result in lethal electric shock.

De-energize PV modules by removing them entirely from light or by covering their front surface with an opaque material. Regard the safety regulations for live electrical equipment when working with modules that are exposed to any light. Use Insulated tools and do not wear metallic jewelry while working with PV modules.

In order to avoid arcing and electrical shock, do not disconnect electrical connections under load. Faulty connections can also result in arcing and electrical shock. Keep connectors dry and clean, and ensure that they are in proper working condition. Never insert metallic objects into the connectors, or modify them in any way in order to secure an electrical connection.

Do not touch or handle PV modules with broken glass, separated frames or a damaged backsheet unless the PV modules are first disconnected and you are wearing proper PPE. Avoid handling PV modules when they are wet unless cleaning the PV modules as directed in this manual. Never touch electrical connections that are wet without protecting yourself with insulated gloves.

Transport and Handling

Yingli Solar PV modules must be transported in the supplied packaging only and kept in the packaging until they are ready to be installed. Protect pallets against movement and exposure to damage during transportation. Secure pallets from falling over. Do not exceed the maximum height of pallets to be stacked, as indicated on the pallet packaging. Store pallets in a cool and dry location until the PV modules are ready to be unpackaged.

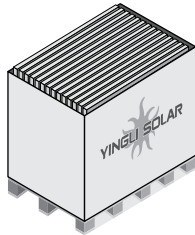

Figure 2: Pallet of PV modules

Yingli Solar PV modules are heavy, and should be handled with care. PV modules shall be handled at the frame; never use the junction box or cables as a grip. Do not exert mechanical stress on the cables. Never step on PV modules or drop or place heavy objects on them. Be careful when placing PV modules on hard surfaces, and secure them from falling. Broken glass can result in personal injury. PV modules with broken glass cannot be repaired and must not be used. Broken or damaged PV modules must be handled carefully and disposed of properly.

For unpacking PV modules from the Yingli Solar supplied packaging, first remove the pallet lid (after removing securing straps, if provided). Remove PV modules one at a time by sliding them up the channel in the package (see Figure 3). You may need to secure the remaining PV modules in the pallet packaging to prevent them from falling over.

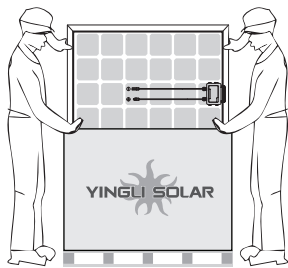

Figure 3: Removing PV modules from a pallet

Check PV modules for damage due to transportation before they are installed; do not install damaged modules. Contact the company you purchased the Yingli Solar PV modules from in order to obtain information on making claims for defective PV modules.

PV module surfaces are susceptible to damage that could affect the performance or safety of the PV module; do not damage or scratch the PV module surfaces, and do not apply paint or adhesive to any of the surfaces, including the frame. For your safety, do not disassemble or modify Yingli Solar PV modules in any way. Doing so may degrade performance or cause irreparable damage and will void any applicable warranties.

If it is necessary to store PV modules prior to installation, the PV modules should remain inside the packaging and protected from exposure that could compromise the durability of the packaging.

Fire

Yingli Solar PV Modules have a Class C fire resistance rating in accordance with UL 1703 certification. When PV modules are mounted on rooftops, the roof must have a fire resistant covering suitable for this application. PV modules are electrical generating devices that may affect the fire safety of a building.

The use of improper installation methods and/or defective parts may result in the unexpected occurrence of an electrical arc during operation. In order to mitigate the risk of fire in this event, PV modules should not be installed near flammable liquids, gases, or locations with hazardous materials.

In the event of a fire, PV modules may continue to produce a dangerous voltage, even if they have been disconnected from the inverter, have been partly or entirely destroyed, or the system wiring has been compromised or destroyed. In the event of fire, inform the fire crew about the particular hazards from the PV system, and stay away from all elements of the PV system during and after a fire until the necessary steps have been taken to make the PV system safe.

APPLICATION INFORMATION

Application Restrictions

Yingli Solar PV modules must be mounted on appropriate mounting structures positioned on suitable buildings, the ground, or other structures suitable for PV modules (e.g. carports, building facades or PV trackers). PV modules must not be mounted on moving vehicles of any kind. Yingli Solar PV modules must not be installed in locations where they could be submerged in water.

Yingli Solar PV modules must not be sited in locations where aggressive substances such as salt or salt-water, or any other type of corrosive agent, could affect the safety and/or performance of the PV modules. Although Yingli Solar PV modules have passed the IEC 61701 salt-mist corrosion test with a salt concentration of 5% by weight, galvanic corrosion can occur between the aluminum frame of the PV module and mounting or grounding hardware if such hardware is comprised of dissimilar metals. Yingli Solar recommends that only stainless steel and aluminum metal directly contact PV modules in seaside installations to limit corrosion.

Artificially concentrated light must not be directed on Yingli Solar PV modules.

Design Recommendations

Yingli Solar recommends that PV modules be mounted at a minimum tilt angle of 10 degrees to allow for proper self-cleaning from normal rain showers.

Partial or complete shading of a PV module or modules can significantly reduce system performance. Yingli Solar recommends minimizing the amount of shade throughout the year to increase the amount of energy produced by the PV modules.

Lightning protection is recommended for PV systems that are to be installed in locations with high probability of lightning strikes.

ELECTRICAL INSTALLATION

Electrical Configuration

Under normal conditions, a photovoltaic module is likely to experience conditions that produce more current and/or voltage than reported at Standard Test Conditions (STC: 1000 W/m², AM 1.5, and 25°C cell temperature). As required by the US National Electric Code (NEC), the short-circuit current (ISC) should be multiplied by a factor of 1.25 and the open-circuit voltage (VOC) should be multiplied by a factor of up to 1.25 based on the lowest ambient temperature recorded for the installation location when determining component voltage ratings, conductor current ratings, fuse sizes, and size of controls connected to the PV output. Follow Section 690.7 in the (NEC) to determine the adjusted system voltage value.

Refer to Section 690.8 of the NEC for an additional multiplying factor of 125 percent (80 percent de-rating) which may be applicable for sizing fuses and conductors.

Voltages are additive when PV modules are connected directly in series, and module currents are additive when PV modules are connected directly in parallel, as illustrated in Figure 4. PV modules with different electrical characteristics must not be connected directly in series. The use of suitable third-party electronic devices connected to PV modules may enable different electrical connections and must be installed according to the manufacturer's specified instructions.

Series Wiring (Voltage Additive)

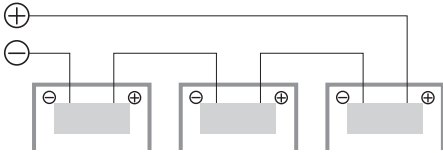

Parallel Wiring (Current Additive)

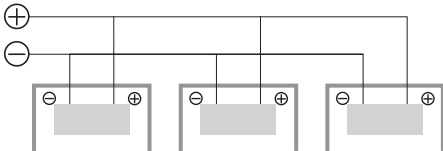

Figure 4: Electrical diagrams of series and parallel wiring

The maximum number of PV modules that can be connected in a series string must be calculated in accordance with applicable regulations in such a way that the specified maximum system voltage of the PV module and all other electrical DC components will not be exceeded in open-circuit operation at the lowest temperature expected at the PV system location.

An appropriately rated overcurrent protection device must be used when the reverse current could exceed the value of the maximum fuse rating of the module. An overcurrent protection device is required for each series string if more than two series strings are connected in parallel.

Cables and Wiring

Yingli PV modules are provided with two (2) stranded, sunlight resistant output cables that are terminated with PV connectors ready for most installations. The positive (+) terminal has a female connector while the negative (-) terminal has a male connector. The module wiring is intended for series connections (i.e. female (+) to male (-) interconnections), but can also be used to connect suitable third-party electrical devices that may have alternative wiring configurations so long as the manufacturer's instructions are followed.

Use field wiring with suitable cross-sectional areas that are approved for use at the maximum short-circuit current of the PV module. Yingli Solar recommends installers use only sunlight resistant cables qualified for direct current (DC) wiring in PV systems. The minimum wire size should be 12 AWG.

	Type	Wire Size	Temperature Rating
Required Minimum Field Wiring	USE-2 or PV Wire	12 AWG	-40°C to +90°C

Table 1: Required minimum field wiring specifications

Cables should be fixed to the mounting structure in such a way that mechanical damage of the cable and/or the module is avoided. Do not apply stress to the cables. For fixing, use appropriate means, such as sunlight resistant cable ties and/or wire management clips specifically designed to attach to the PV module frame. While the cables are sunlight resistant and waterproof, where possible, avoid direct sunlight exposure and water immersion of the cables.

Connectors



Keep connectors dry and clean, and ensure that connector caps are hand tight. Do not attempt making an electrical connection with wet, soiled, or otherwise faulty connectors. Avoid sunlight exposure and water immersion of the connectors. Avoid connectors resting on the ground or roof surface.

Faulty connections can result in arcs and electrical shock. Check that all electrical connections are securely fastened. Make sure that all locking connectors are fully engaged and locked.

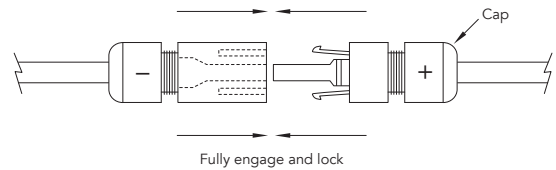

Figure 5: Series interconnection of a male (-) and female (+) connector

The junction boxes used with Yingli Solar PV modules contain bypass diodes wired in parallel with the PV cell strings. In the case of partial shading, the diodes bypass the current generated by the non-shaded cells, thereby limiting module heating and performance losses. Bypass diodes are not overcurrent protection devices.

Bypass diodes divert current from the cell strings in the event of partial shading. See Figure 6 for a diagram showing how the cell strings are electrically connected with the diodes.

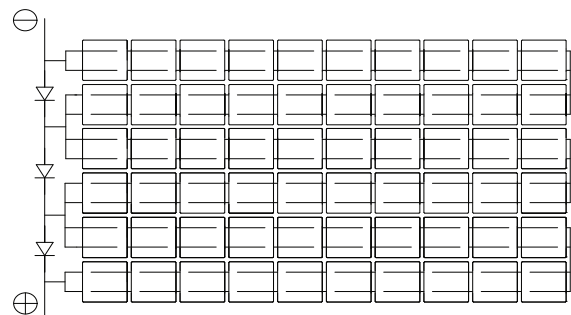

Figure 6: Electrical circuitry of cells and bypass diodes

In the event of a known or suspected diode failure, installers or maintenance providers should contact the company the PV modules were purchased from. Never attempt to open the junction box of a Yingli Solar PV module yourself.

Equipment Grounding

The frame of the PV module, as well as any exposed non-current-carrying metal parts of fixed equipment that are able to become energized by the PV system, must be connected to the equipment grounding conductor in order to prevent electrical shock. Refer to section 250 of the NEC for specific instructions on grounding. Even when applicable regulations, code requirements, and standards do not require safety-related grounding, Yingli Solar recommends grounding all PV module frames in order to ensure the voltage between electrically conductive equipment and earth ground is zero in all circumstances.

Proper equipment grounding is achieved by bonding all exposed non-current-carrying metal equipment continuously to one another using an appropriately sized equipment grounding conductor (EGC) or racking system that can be used for integrated grounding (see Option C in Grounding Methods below).

Yingli Solar PV modules employ a coated aluminum frame for corrosion resistance. In order to properly ground the module frame, the coating must be penetrated.

The potential for corrosion due to the electrochemical action between dissimilar metals in contact is minimized if the electrochemical voltage potential between the dissimilar metals is low. The grounding method must not result in the direct contact of dissimilar metals with the aluminum frame of the PV module that will result in galvanic corrosion. An addendum to UL 1703 recommends metal combinations not exceed an electrochemical potential difference of 0.5 Volts.

The frame rails have pre-drilled holes marked with a grounding sign, as illustrated in Figure 7. These holes should be used for grounding purposes and must not be used for mounting the PV modules. Do not drill additional holes into the frame rails.

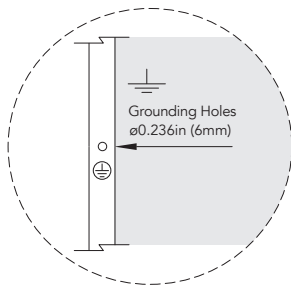

Figure 7: Grounding hole detail

The following grounding methods are available:

Option A: Grounding Lugs

Manufacturer	Part Number	Material	Tightening Torque
ILSCO	GBL-4DBT	Tin-plated copper	20 to 25 in-lbf (2.3 to 2.6 N-m)
Burndy®	CL501-TN	Tin-plated copper	20-25 in-lbf (2.3 to 2.6 N-m)
Tyco Electronics	SolKlip 1954381-4	Nickel and tin-plated copper	15 +4.4/-1.7 in-lbf (1.7+0.5/-0.2 N-m)

Table 2: Grounding lug specifications

Installation of grounding lugs must be in accordance with the specified instructions of the respective manufacturers. A grounding lug must be attached at a designated grounding hole location using #10 stainless steel hardware. A stainless steel toothed lock washer or KEPS Nut is required to adequately engage the frame and penetrate the nonconductive coating. The screw holding the appropriately sized EGC in place must firmly clamp the EGC in order to establish a reliable electrical bond.

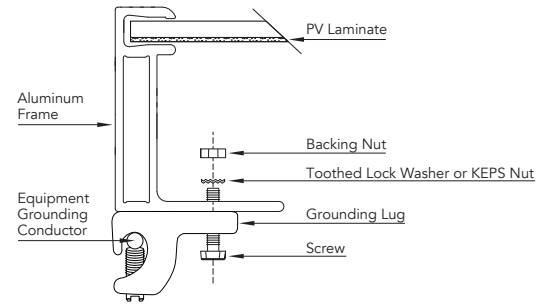

Figure 8: Grounding lug detail

Option B: Screw Assembly

1. A grounding screw assembly must be attached at a designated grounding hole location using only stainless steel hardware. Insert a #10 stainless steel screw first through the stainless steel cup washer, and then through the grounding hole.
2. Loosely engage a stainless steel backing nut and toothed lock washer to the screw.
3. Bend the EGC into an omega (Ω) shape to tightly fit between the partially installed screw head and cup washer. The EGC shall be exclusively in contact with stainless steel.
4. Tighten the screw to 20 in-lbf (2.3 N-m) torque. The toothed lock washer should be visibly engaged to the frame.
5. Route the appropriately sized EGC in such a way as to avoid contact with the aluminum module frame.

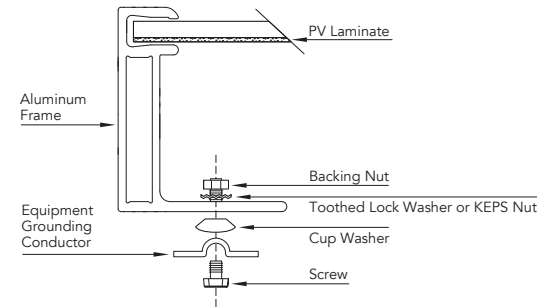

Figure 9: Grounding screw assembly detail

Option C: Racking Manufacturer Integrated Grounding Methods

Yingli Solar PV modules can be grounded by bonding PV modules to a grounded racking system. Integrated grounding methods must be certified to UL 1703 or 2703 for grounding PV modules and must be installed in accordance with the specified instructions of their respective manufacturers.

Option D: Additional Third-party Grounding Devices

Yingli Solar PV modules can be grounded using third party grounding devices so long as they are certified for grounding PV modules and the devices are installed according to the manufacturer's specified instructions.

MECHANICAL INSTALLATION

Mounting structures and other mechanical parts must be designed and approved to withstand the design wind and snow loads applicable for a particular site. Yingli Solar PV modules must not be subjected to forces from the substructure, including forces caused by thermal expansion.

The mounting method must not result in the direct contact of dissimilar metals with the aluminum frame of the PV module that will result in galvanic corrosion. An addendum to UL 1703 recommends metal combinations not exceed an electrochemical potential difference of 0.5 Volts.

Yingli Solar PV modules can be mounted in landscape or portrait orientation, as illustrated in Figure 10, provided that the mounting method follows one of the acceptable methods listed below.

Figure 10: Landscape and portrait mounting

In order to maintain the fire class rating, the distance between the PV module front surface (glass) and the roof surface shall be at least 4 inches (10 cm). This spacing also allows air flow to cool the PV module.

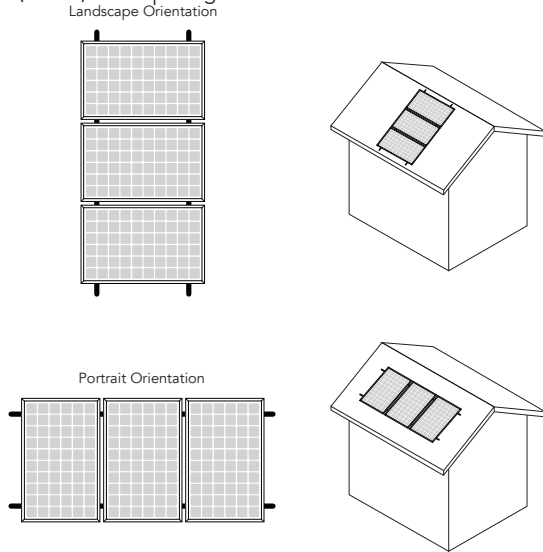

Install PV modules with a minimum spacing of 0.4 inches (1 cm) between neighboring frames to allow for thermal expansion.

Mounting Methods

The following mounting methods are available:

Option A: Bolts or Clamps

Refer to the Module Supplement at the end of this manual to determine how many connection points are required for a specific module series. The locations of mounting holes and clamp tolerances are illustrated in the drawings located in the Module Supplement. Do not modify the existing mounting holes or drill new holes.

- **Bolts:** Modules must be mounted using the mounting holes located on the rear side of the long frame parts using ¼ inch stainless steel bolts, nuts, and washers. Refer to the racking manufacturer for specific torque requirements.

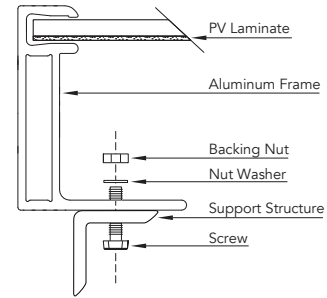

Figure 11: Detail of a bolt mounting attachment

- **Top-down Clamps:** Third-party clamps that have been designed for PV mounting structures are an approved mounting attachment method for Yingli Solar PV modules. Modules must be fastened using clamps applied to the top side of the long frame parts. A clamp holds two modules except for the clamps at the beginning and end of a module row. The centerline of the clamps must be in line with the mounting hole positions plus or minus a distance of two (2) inches (50mm). Clamps must be installed according to the manufacturer's specified instructions. Do not apply excessive pressure on the frame such that the frame deforms. Refer to the clamp manufacturer for specific hardware and torque requirements.

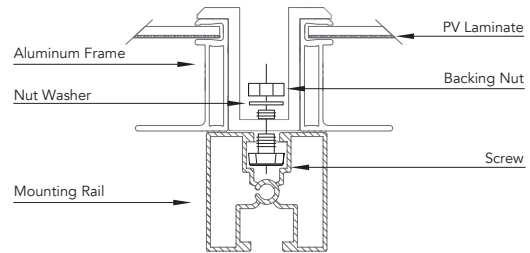

Figure 12: Detail of a top-down clamp mounting attachment

Option B: PanelClaw™ Attachment System

Attachment with the PanelClaw system is permitted for Yingli Solar PV modules listed in the Module Supplement. Support structures manufactured by PanelClaw, Inc. employ a special clamp, or "claw" (Part Number: 500-0005) designed to attach to the flange of the PV module at each of the four corners, on the two short frame members.

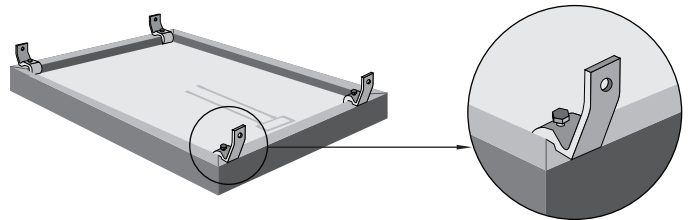

Figure 13: Detail of claw placement

For proper attachment, place a claw over the PV module frame flange at each of the four designated locations and tighten the stainless steel 3/8-16 x 1.25" hex head cap screw to a torque pressure between 18 ft.lbf (24.4 N.m) and 20 ft.lbf (27.1 N.m). Ensure that the claws are flush with both the long and short lengths of the PV module flange. This mounting method has been tested for a maximum static load of 30 psf (2400 Pa) in both the positive and negative directions.

INSTALLATION OF YGE-Z SERIES ZEP COMPATIBLE MODULES

Yingli Solar offers the YGE-Z Series PV module which features a modified aluminum frame that is compatible with mounting and grounding hardware manufactured by Zep Solar. Refer to the 'YGE-Z Series Installation Supplement' for installation information. Detailed design and installation information of Zep Solar's mounting systems can be found at <http://www.zepsolar.com/resources.html>. The YGE-Z Series PV module warranty will become void if non-Zep-certified hardware is attached inside the Zep Groove of the module frame.

YGE-Z Series PV modules are also compatible with the mounting and grounding methods included in this manual.

MAINTENANCE

Yingli Solar recommends that PV systems be periodically inspected by the installer, or other qualified person.

The purpose of the PV system inspection is to ensure that all system components are functioning properly. At a minimum, this inspection should confirm the following:

- All cables and connector attachments are undamaged and properly secured
- No sharp objects are in contact with the PV module surfaces
- PV modules are not shaded by unwanted obstacles and/or foreign material
- Mounting and grounding components are tightly secured with no corrosion

Defects should be addressed immediately.

Cleaning

Over time, dirt and dust can accumulate on the glass surface of the module, reducing its power output. Yingli Solar recommends periodic cleaning of PV modules to ensure maximum power output, especially in regions with low precipitation.

In order to reduce the potential for electrical and thermal shock, Yingli Solar recommends cleaning PV modules during early morning or late afternoon hours when solar radiation is low and the modules are cooler, especially in regions with hotter temperatures.

Never attempt to clean a PV module with broken glass or other signs of exposed wiring, as this presents a shock hazard.

Clean the glass surface of the PV modules with a soft brush using soft, clean water with a recommended pressure less than 100psi (690kPa), which is typical of most municipal water systems. Water with high mineral content may leave deposits on the glass surface and is not recommended.

Yingli Solar PV modules may contain a hydrophobic anti-reflective coating on the glass surface to enhance power output and reduce dirt and dust buildup. In order to avoid module damage, do not clean PV modules with a power washer or pressure washer. Do not use steam or corrosive chemicals to facilitate the cleaning of modules. Do not use aggressive tools or abrasive materials that could scratch or damage the glass surface. Failure to comply with these requirements may adversely affect the PV module performance.

Yingli Solar PV modules are designed to withstand high snow loads. However, if removing snow is desired to enhance production, use a brush to gently remove snow. Do not try to remove frozen snow or ice from PV modules.

DECOMMISSIONING

The dismantling of PV systems must be performed with the same care and safety precautions used during the initial installation. The PV system can generate hazardous voltage even after the system has been disconnected. Follow safety regulations for working with live electrical equipment.

Module Supplement

Revision Date Aug 26, 2011 | Applicable for UL certified products in the United States and Canada.

This supplement refers to modules of the following types:

FAMILY	YGE 240 SERIES	YGE-Z SERIES	YGE 285 SERIES	PANDA SERIES
TYPE	YL225P-29b	YL225P-29b	YL270P-35b	YL250C-30b
	YL230P-29b	YL230P-29b	YL275P-35b	YL255C-30b
	YL235P-29b	YL235P-29b	YL280P-35b	YL260C-30b
	YL240P-29b	YL240P-29b	YL285P-35b	YL265C-30b

MOUNTING REQUIREMENTS

Mounting Method Option A: Bolts and Clamps

Modules that Require Four (4) Connection Points	The Following Modules Require Eight (8) Connection Points for Installations that Exceed 50 psf (2400 Pa) Loading
YGE 240 SERIES	YGE 285 SERIES
YGE-Z SERIES	
YGE 285 SERIES*	
PANDA SERIES	

* Connections are required at the four outer mounting holes

Mounting Method Option B: PanelClaw™ Attachment System

PanelClaw™ Approved Modules
YGE 240 SERIES
PANDA SERIES

Installation Method: Zep Solar Mounting Systems

ZSI, ZSII, ZSIII
YGE-Z SERIES*

* Refer to "YGE-Z Series Installation Supplement" for additional information

ELECTRICAL CHARACTERISTICS

Nameplate ratings are average values. The electrical characteristics are within +/- 10 percent of the indicated values of Isc, Voc, and Pmax under Standard Test Conditions (irradiance of 100 W/m², AM 1.5 spectrum, and a cell temperature of 25°C). Refer to module datasheets for specific power output tolerance.

Module family	Module type	Power output	Voltage at Pmax	Current at Pmax	Open-circuit voltage	Short-circuit current	Max. DC system voltage	Max. series fuse rating
		P _{max}	V _{mpp}	I _{mpp}	V _{oc}	I _{sc}		
		[W]	[V]	[A]	[V]	[A]	[V]	[A]
YGE 285 SERIES	YL285P-35b	285	35.5	8.02	45.0	8.50	600	15
	YL280P-35b	280	35.5	7.89	45.0	8.35	600	15
	YL275P-35b	275	35.5	7.75	45.0	8.30	600	15
	YL270P-35b	270	35.3	7.65	44.8	8.20	600	15
YGE 240 SERIES & YGE-Z SERIES	YL240P-29b	240	29.5	8.14	37.5	8.65	600	15
	YL235P-29b	235	29.5	7.97	37.0	8.54	600	15
	YL230P-29b	230	29.5	7.80	37.0	8.40	600	15
	YL225P-29b	225	29.5	7.63	36.5	8.28	600	15
PANDA SERIES	YL265C-30b	265	31.0	8.55	39.0	8.93	600	20
	YL260C-30b	260	30.8	8.46	38.6	8.91	600	20
	YL255C-30b	255	30.6	8.33	38.2	8.85	600	20

REAR AND SIDE VIEW DIMENSIONS OF MODULE SERIES

UNITS: INCH (mm)

YGE 240 SERIES

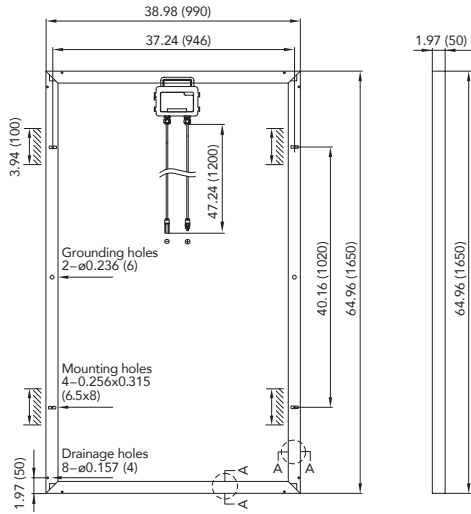

PANDA SERIES

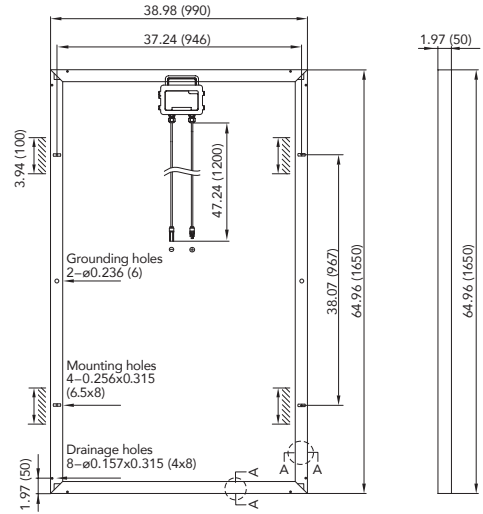

YGE285 SERIES

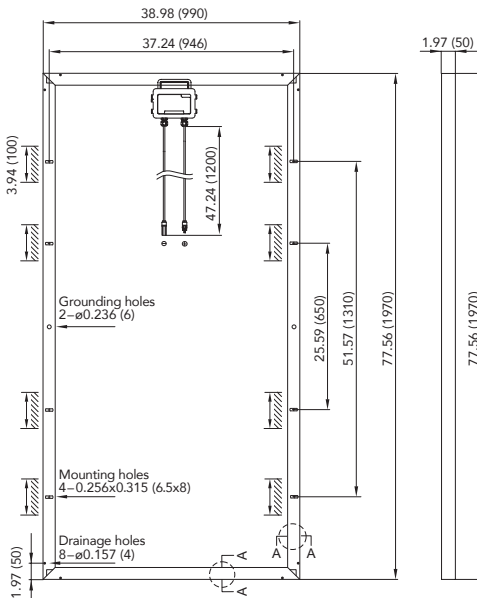

YGE-Z SERIES

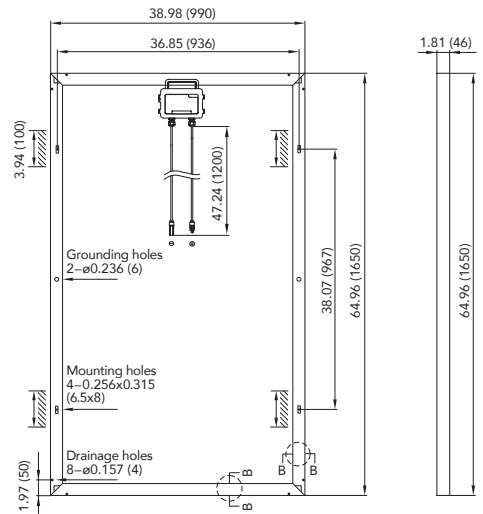

Frame Cross Section

YGE-Z Frame Cross Section

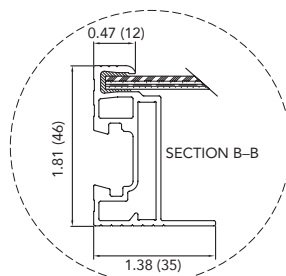
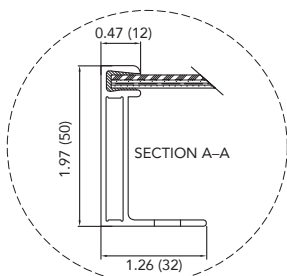

Legend

- Grounding holes
- ⊕ Mounting holes
- Drainage holes
- ▨ Mounting tolerance